



The Ultimate  
in Solid Fuel Heating

# Wood/Coal Furnaces



*(Model 385EK Wood Furnace pictured)*

Manufactured exclusively in Chippewa Falls, WI USA

© 2010 RJM Manufacturing, Inc.

[www.energyking.com](http://www.energyking.com)

## ENERGY INDEPENDENCE

For over 30 years, **ENERGY KING** solid-fuel heating appliances have provided homeowners with energy independence by offering high-quality, long-lasting solid-fuel home heating options. By choosing to heat their homes with domestically-produced solid-fuel, owners of **ENERGY KING** heating appliances are choosing energy independence!

**ENERGY KING** Wood/Coal Furnaces are designed to be used independently or as an add-on to your existing central heating system, and burn either air-dried wood, or anthracite or bituminous coal.

**Wood:** Burning wood for heat is as old as civilization itself. More than any other major fuel, wood provides us with energy independence – an easily available, locally produced and renewable source of heat on which we can rely.

**Coal:** One of the world's most widely-used fuel sources, coal can provide the energy independence and low fuel prices sought by owners of solid-fuel heating appliances.

## SAFETY & RELIABILITY

**ENERGY KING** Wood/Coal Furnaces are constructed of heavy 1/4", 7 gauge and 10 gauge steel plate, and welded by experienced and certified welders to ensure safety and durability.

**ENERGY KING** Wood/Coal Furnaces also feature durable 1700-degree firebrick and heavy cast iron grates and doors for increased longevity.

All **ENERGY KING** Wood/Coal Furnaces are tested to UL391 standards by Intertek Testing of Middleton, WI. You can rest easy knowing that **ENERGY KING** Wood/Coal Furnaces conform to an internationally recognized standard for safety and quality.

## WARRANTY

**ENERGY KING** Wood/Coal Furnaces are quality backed with a 6-year limited warranty on materials and workmanship. Castings and electrical components are backed by their manufacturers' warranties. Firebrick and gaskets are not warranted. A copy of the **ENERGY KING** warranty is available in every **ENERGY KING** *Installation, Operation & Maintenance Manual*, and is available online at [www.energyking.com](http://www.energyking.com).

## SIZING

It is important to choose a solid-fuel heating appliance that is correctly sized for your home. A slightly undersized wood/coal furnace will generally require short, hot fires which burn cleaner and more efficiently than the slow-burning or smoldering fires generated in an oversized wood/coal furnace. Additionally, slow-burning or smoldering fires could contribute to dangerous creosote buildup.

The estimated heating capacities of **ENERGY KING** Wood/Coal Furnaces are:

- up to 1,500 square feet (model 365EK)
- up to 2,000 square feet (model 385EK)
- up to 2,500 square feet (model 480EK)

In addition to square footage, some of the factors that may affect your heating needs are your home's age, design, and geographic location (climate). Other factors to consider are your chimney's draft strength and whether you plan to burn wood or coal as your primary fuel source.

A general rule-of-thumb is to choose a solid-fuel furnace that has a similar BTU output to your current (conventional) furnace.

## ABOUT ENERGY KING

American-made with pride for over 30 years, **ENERGY KING** heating appliances have maintained a commitment to providing quality solid-fuel home heating options. Our experienced engineers know what it takes to build solid, long-lasting central heating equipment. We use the latest technology to design and build our products, with particular attention to safety, efficiency, reliability, and ease of use. Our ultimate goal is to combine these aspects to guarantee our customers a solid product built for a lifetime of top performance.

**ENERGY KING** solid-fuel heating appliances continue to be manufactured exclusively in Chippewa Falls, WI USA.

**ENERGY KING**<sup>™</sup> is a trademark of RJM Manufacturing, Inc.

## FEATURES

Not all features are labeled on cutaway drawings, however all features apply to all models unless otherwise noted.

- 1 Thermostatically-controlled Draft:** The Furnace's burn rate is controlled by a 24-V Wall Thermostat located in the living area of the home, and either automatic or forced air draft. Also available is a manual draft control, which is not thermostatically-controlled (365EK only).
- 2 1800CFM/3-Speed Circulation Blower** is standard. An optional filter box kit is available.
- 3 Cast Iron Grates:** Stationary cast iron grates are standard. Optional cast iron shaker grates featuring an externally mounted shaker handle are available.
- 4 Insulated Cabinet:** The enameled steel cabinet panels (sides and top) restrain a foil-backed insulation blanket, allowing maximum heat from the Furnace to be transferred into your home's heating system.
- 5 Removable Ash Pan.**
- 6 6" Chimney Outlet:** **ENERGY KING** Wood/Coal Furnaces feature a 6" chimney outlet to vent smoke and flue gases that are a natural result of combustion. Venting must be provided using a lined masonry chimney or a listed UL103 type HT factory-built chimney.
- 7 Cast Iron Hearth Plates:** Located at the front and rear of the burn chamber, these plates help to promote efficient combustion by introducing the precise amount of combustion air into the burn chamber.
- 8 Firebrick:** Durable 1700-degree, heat retentive firebrick protects the **ENERGY KING** Wood/Coal Furnace's burn chamber, and helps to maintain high internal temperatures for more efficient and complete combustion. *Model 385EK: Sides, Top & Back. Models 365EK/480EK: Lower sides only.*
- 9 Heavy Cast-Iron Doors:** **ENERGY KING** Wood/Coal Furnaces feature heavy cast iron fuel loading and ash removal doors. Additionally, the model 385EK Wood/Coal Furnace features a glass viewing port located on the fuel loading door.
- 10 Secondary Heat Exchanger:** The secondary heat exchanger recovers heat that would normally exit through the chimney. The model 385EK Wood/Coal Furnace features a unique tubular secondary heat exchanger with over 23 square feet of heat transfer area.
- 11 Bypass Damper Control** for easy startup.
- 12 Secondary Combustion Air:** (Model 385EK only)  
An air tube delivers super-heated secondary combustion air into the burn chamber, igniting gases and particulates that would normally be released as smoke through the chimney.

## MODEL: 385EK

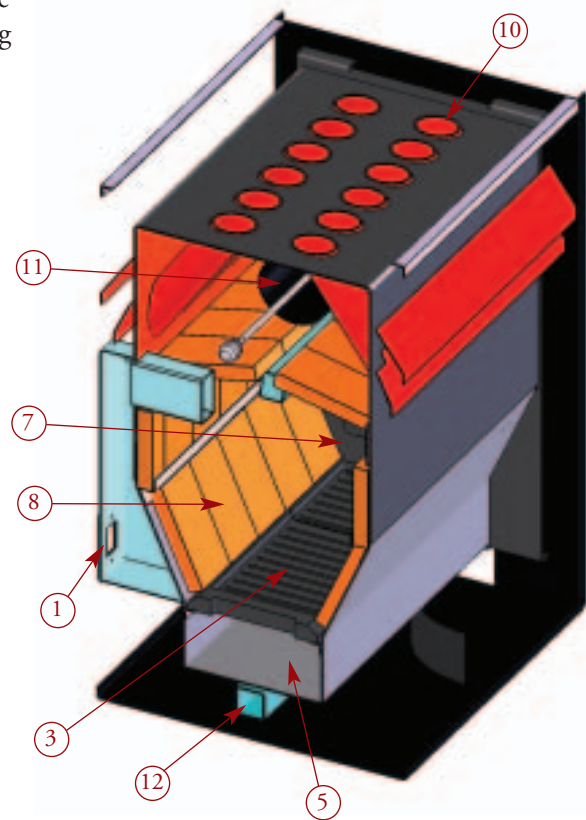

## MODELS: 365EK, 480EK

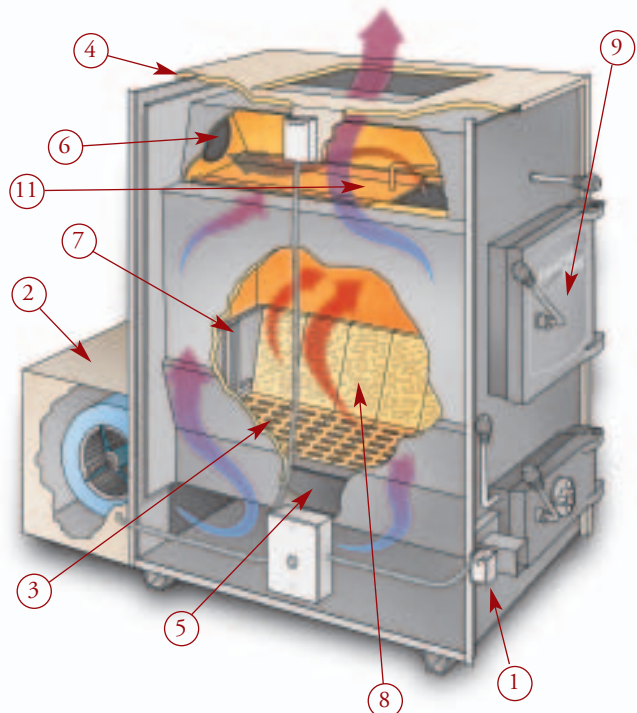

# ENERGY KING Wood/Coal Furnaces Specifications

MODEL	385EK	365EK	480EK
Overall Dimensions (H x W x D)	49" x 26.5" x 53"	48" x 26" x 53"	51.5" x 26" x 60"
Cabinet Dimensions (H x W x D)	49" x 26.5" x 33"	48" x 26" x 35"	51.5" x 26" x 42"
Shipping Weight (approx.)	875 lbs.	650 lbs.	725 lbs.
Heating Capacity - BTU's (approx.)*	125,000	125,000	160,000
Heating Area (approx.)*	2,000 sq. ft.	1,500 sq. ft.	2,500 sq. ft.
Efficiency	78% (Automatic Draft only)	N/A	N/A
Log Length	22"	21"	26"
Sliding Smoke Baffle	Standard	Standard	Standard
Secondary Combustion Air	Standard	N/A	N/A
Secondary Heat Exchanger	Tubular	Standard	Standard
Cast Iron Fuel Loading Door Size (H x W)	12.5" X 14" with glass viewing port	15.5" X 13.5"	15.5" X 13.5"
Cast Iron Ash Removal Door Size (H x W)	7.25" x 11.5"	7.25" x 11.5"	7.25" x 11.5"
Removable Ash Pan	Standard	Standard	Standard
Flue Size**	6"	6"	6"
Flue Collar Height** (to top)	43"	45"	48.25"
Leg Height	3.5"	3.5"	3.5"
Plenum Outlet Size	18" x 18"	18" x 18"	20" x 20"
Insulated Cabinet	Standard	Standard	Standard
Double Wall Back	Standard	Standard	Standard
Prewired Electrical Components	Standard	Standard	Standard
Draft Controls	Automatic (standard) or Forced (optional)	Automatic (standard) or Manual (optional)	Automatic or Forced (choice)
Wall Thermostat	Standard	Standard	Standard
3-Speed Blower Capacity	1400-1600-1850CFM	1400-1600-1850CFM	1400-1600-1850CFM
Filter Box	Optional	Optional	Optional
Cast Iron Stationary (Wood) Grates	Standard	Standard	Standard
Cast Iron Shaker (Coal) Grates	Optional	Optional	Optional
Cast Iron Hearth Plates (Front & Rear)	Standard	Standard	Standard
Domestic Hot Water Tube	N/A	Optional	Optional
Warranty***	6 Year Limited	6 Year Limited	6 Year Limited
Complies with Standards	UL391	UL391	UL391

\*The heating capacity specifications are provided as guidelines only and in no way guarantee the output or capacity of the units. The actual BTU output depends on the type of fuel being burned and its condition, the thermostat setting, the draft adjustments and the chimney into which the unit is installed.

\*\*All units require installation into a lined masonry chimney or a listed 6" UL-103 Type HT factory-built chimney. Do not connect this appliance to a chimney flue serving another appliance. It is the consumer's responsibility to make certain that both the appliance and installation are acceptable to their insurance company, as well as ensuring compliance with all local, state and national codes and regulations.

\*\*\*Quality backed with a 6 year limited warranty on materials and workmanship. Castings and electrical are backed by their manufacturers' warranties. Firebrick and gaskets are not warranted. A copy of the **ENERGY KING** warranty is available in every **ENERGY KING Installation, Operation & Maintenance Manual**, and is available online at [www.energyking.com](http://www.energyking.com).

**We are constantly improving and updating our products in order to provide the highest quality and value possible. We reserve the right to make changes and improvements without notice.**



Dealer: